

**JG Speedfit®**

**UNDERFLOOR**

Simple. Smart. Solutions.

# ROOM PACK





# 1. Room Pack Overview

# 2. Temperature Settings

# 3. Operation

# 4. Wiring

# 5. Installing Your Room Pack

- Before you get started
- Preparing the floor
- Installing the control unit
- Laying underfloor heating pipe circuits
- Connecting the control unit to the pipe circuit
- Connecting to an existing heating system
- Laying the floor screed
- Installing JG Aura heating controls (thermostat)

# 6. Help & Support

# 1. Room Pack Overview

Speedfit Underfloor Room Packs provide underfloor heating at affordable prices and are ideal for single rooms up to 30m<sup>2</sup>, including conservatories, bathrooms, kitchens and extensions.

- Cost-effective solution for single rooms up to 30m<sup>2</sup>
- Fast and simple to install
- High heat output and response
- Ideal for new builds and extensions
- Suitable for solid concrete or beam and block subfloors
- Timber floors (additional components may be required)

## Room Pack Contents

Each pack comes with the following essential components:

### JG Single Control Unit

For quick and easy installation, the control unit is pre-assembled and wired and comes complete with a wall fixing kit. The pump is pre-wired in conjunction with a flow temperature thermostat and mains connection cable. The unit includes:

- Ball valves to connect/isolate the primary heating system
- Adjustable, pre-wired thermostatic blending valve
- Integral 7 meter Grundfos UPM3 circulating pump
- Push-fit flow and return connections
- Anti-vibration mounting bracket for silent operation

### Programmable Room Thermostat

A stylish thermostat with intuitive menus makes it easy to set the room time and temperature.

### JG Layflat<sup>®</sup> Pipe and Staples

Ultra flexible and lightweight, JG's Polybutylene pipe is ideal for laying underfloor heating pipe circuits and is secured to the insulation using the staples provided.

# Choosing the Right Pack

There are three Room Packs to choose from depending on the floor area and type of heating control required.

## 20m<sup>2</sup> Room Pack:

- 1 x single room control unit
- 1 x programmable room thermostat (230v)
- 1 x 15mm x 150m coil of Polybutylene pipe
- 200 x pipe staples
- 2 x pipe inserts



---

## 30m<sup>2</sup> Room Pack:

- 1 x single room control unit
- 1 x programmable room thermostat (230v)
- 2 x 15mm x 100m coils of Polybutylene pipe
- 300 x pipe staples
- 8 x pipe inserts
- 2 x 15mm equal tees
- 2 x 15mm stem elbows



---

## 30m<sup>2</sup> Wireless Room Pack:

- 1 x single room control unit
- 1 x programmable room thermostat (wireless)
- 1 x wireless boiler receiver
- 1 x wireless coordinator
- 2 x 15mm x 100m coils of Polybutylene pipe
- 300 x pipe staples
- 8 x pipe inserts
- 2 x 15mm equal tees
- 2 x 15mm stem elbows



# 2. Temperature Settings

The thermostatic blending valve has a temperature setting range between 35°C and 60°C.

Blending Valve Setting	Water Temperature
Min	35°C
1	40°C
2	44°C
3	48°C
4	50°C
5	54°C
6	58°C
Max	60°C

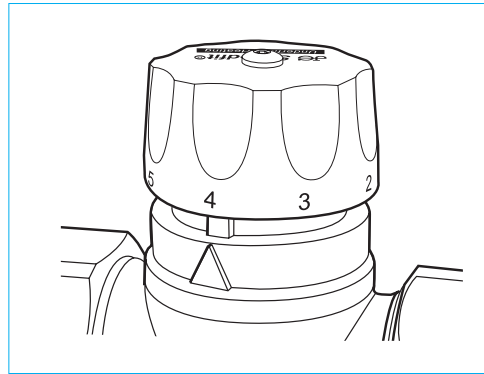

The initial setting of the thermostatic blending valve (after the heat up/screed drying period) should provide the following flow temperatures.

**Screed floors 40 - 45°C**

**Timber floors 55 - 60°C**

These initial settings can be adjusted to provide comfort. A maximum floor surface temperature of 29°C should not be exceeded (except for wet areas such as bathrooms).

With timber floor finishes, including laminate products, the maximum floor temperature of 27°C should not be exceeded as this may result in the material shrinking.

# 3. Operation

When the primary heating circuit is on and there is power to the control unit, a minimum temperature can be selected at which the pump is activated and the heating water is fed through the underfloor heating pipe circuit. The control unit detects hot water arriving from the boiler using a thermostat inside a dry pocket within the flow isolation elbow.

The dial on the pump control thermostat is used to select from a number (see values below) of minimum temperatures at which the pump is activated. The LED is lit when the pump is on.

Pump Operation Temperature:

Pump Control Thermostat Setting	Pump Operation Temperature
1	35°C
2	40°C
3	45°C
4	50°C

**Test = For commissioning purposes only, in this position the pump is always on.**

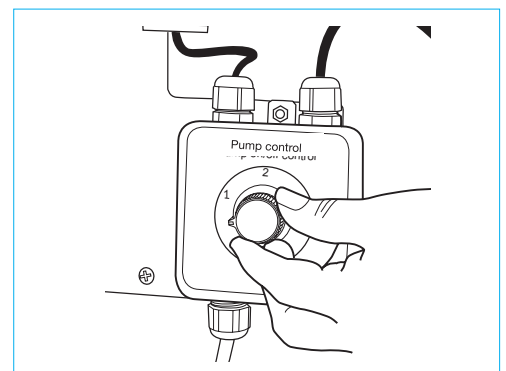

The blending valve will maintain the temperature of the heating circuit by continually blending the flow from the boiler with the cooler return flow from the circuit. The heat output can be adjusted with the control knob on the blending valve to suit different floor structures and comfort levels. (see 2. Temperature settings)

The pump will continue to run until the primary heating water temperature drops 5°C lower than the set temperature on the control pump thermostat.



# 4. Wiring

All wiring should be undertaken by a qualified installer and confirm to IEE regulations. The pump is supplied with a plug-in cable already connected for ease of installation. A fused spur should be installed adjacent to the unit. The mains cable should be connected to the spur fused at 3 amps.

To comply with IEE Regulations, the pump on the unit is provided with an earth connection via the connection box.

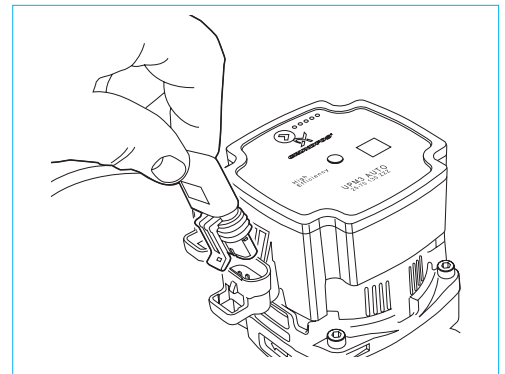

# 5. Installing Your Room Pack

## Before you get started

### Project essentials

- Check maximum area to be heated is 30m<sup>2</sup> (or 20m<sup>2</sup> for the smaller Room Pack)
- Check the boiler serving the existing central heating system has capacity to take the extra output (2kW to 3kW)
- Install the UFH pipe on a solid floor application, ensuring the sub base is flat to fully support the sheet insulation
- Make sure the floor insulation meets design/building regulations. Insulation should normally be 50mm in depth – ask your architect/building control officer for clarification
- Install the pipework on top of the insulation before the screed is laid. Typically, between 65 and 75mm of sand/cement or 50mm liquid screed should be laid on top

### Tools for the job

You will need the contents of your Room Pack as well as the following items:

Tools/Materials	Preparing the floor	Installing the pipe	Laying screed	Installing heating controls
Damp Proof Membrane	•			
Floor Insulation	•			
Speedfit Foil Tape	•			
Speedfit Edge Strip	•			
Polyethylene Film (min 0.15mm)	•			
Sharp Knife	•			
Hand Saw	•			
Speedfit Pipe Cutters		•		
Spacer Baton (optional)		•		
Speedfit Fixing Tool (optional)		•		
Drilling Machine & 8mm Masonry Drill		•		
Sand/Cement Screed			•	
Star Screwdriver				•

# Preparing the floor

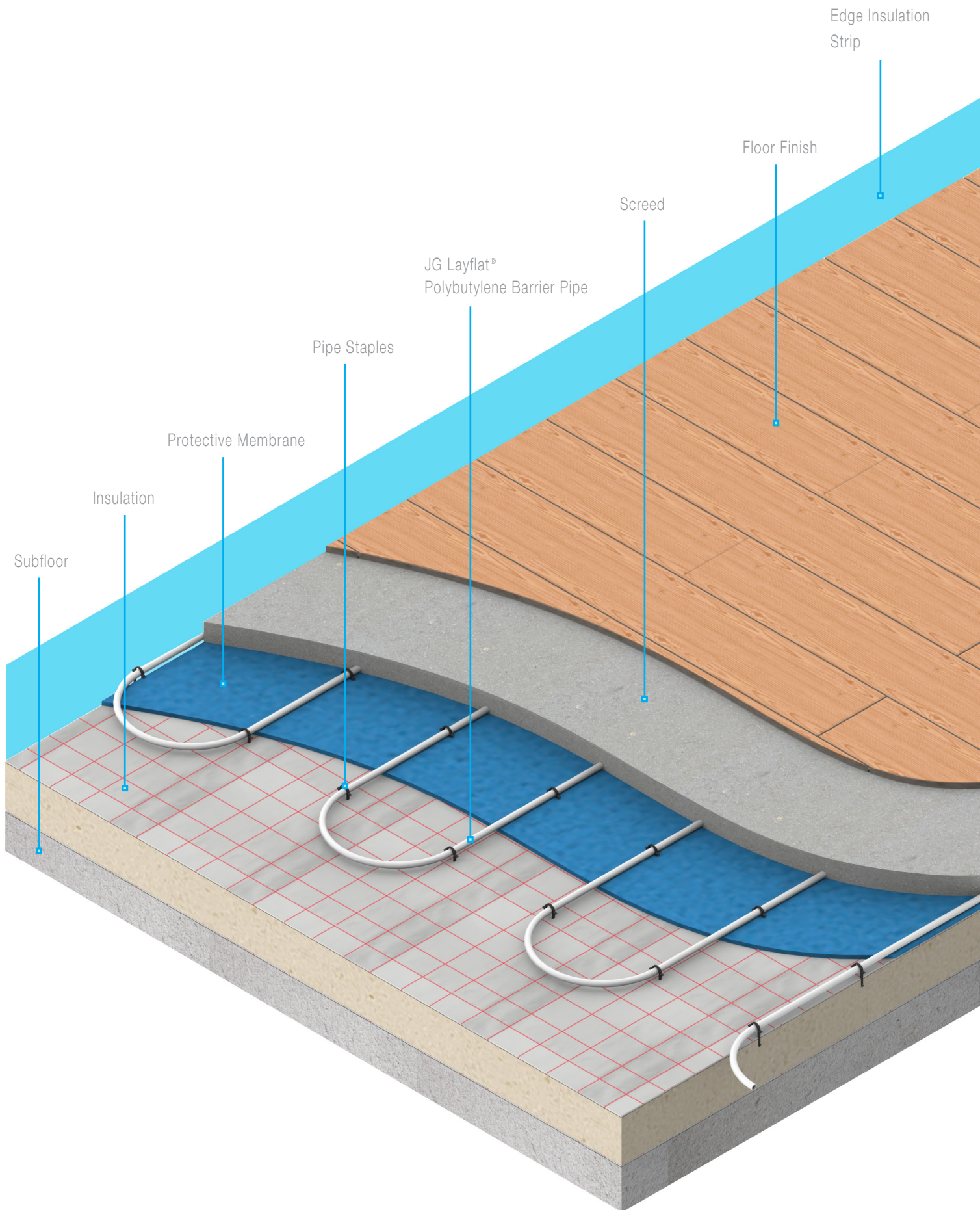

## Step 1

Fit floor insulation on top of the oversite concrete. Make sure the floor insulation meets design/building regulations - typically 100mm in depth.



### ■ Hints & Tips

For extensions with greater heat loss, for example conservatories, you may need extra insulation or supplementary heating.

## Step 2

Apply edge strip round the perimeter of the room by taping it to the edge of the insulation membrane. This will accommodate any expansion that occurs within the screed when it heats up and cools down.



## Step 3

Secure the insulation joints with suitable foil tape.



## Step 4

Lay a polyethylene film over the insulation to create a vapour barrier, which will prevent the screed from contaminating the insulation. The film should be at least 0.15mm thick with a 80mm overlap taped down with tape.





# Installing the control unit

## Step 5

Using the wall bracket, fix the provided control unit to the wall using a hammer drill and 8mm masonry bit. The control unit should be fixed vertically with the mixing valve at either the top or the bottom, or horizontally with the electrical connection box uppermost. Plug the control unit into a suitable socket or wire to a fused spur (3amp fuse).



### ■ Hints & Tips

Always mount the control unit before laying pipework so that you can see clearly where to start and finish the pipe run. Fit the unit to a wall that can bear its weight and ensure adequate clearance and accessibility for the connecting pipework.

# Laying underfloor heating pipe circuits

## Step 6

Install the pipework on top of the insulation before the screed is laid. Starting at the edge of the room, fix the Layflat pipe to the insulation 75mm from the perimeter using the pipe clips supplied.

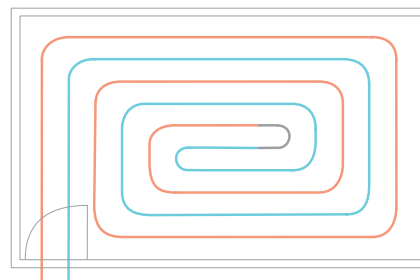

**For rooms under 15m<sup>2</sup>**

## Step 7

Working left to right or right to left, install the first loop working into the centre of the room. For rooms over 15m<sup>2</sup>, the area should be split into 2 loops of pipe covering equal floor areas.

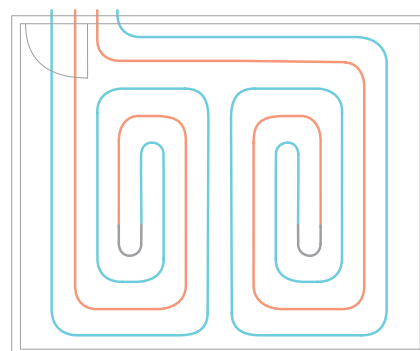

**For rooms over 15m<sup>2</sup>**

## Step 7 continued

Make sure you maintain a consistent space of 200mm between the runs or 150mm for areas with high heat loss. For consistent spacing between runs use an appropriately sized spacer batten:

e.g. 200mm space - 15mm pipe = 185mm spacer batten.



### ■ Hints & Tips

Always feed the pipework from the bottom of the coil. Handle the pipe gently, especially around bends, to prevent it from kinking. You may also need to use additional pipe clips on bends depending on the insulation you are fixing it to.

## Step 8

Cut the end of the pipe using Speedfit pipe cutters and fully insert the pipe insert into the pipe. A twisting motion will aid insertion.

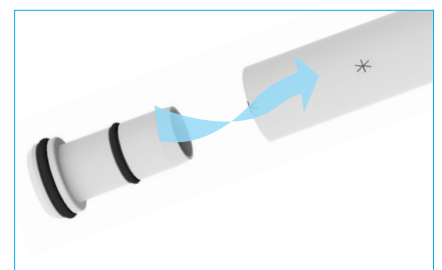

### ■ Hints & Tips

Make sure the pipe is free of score marks.  
Cut the pipe square to ensure a secure connection.



# Connecting the control unit to the pipe circuit

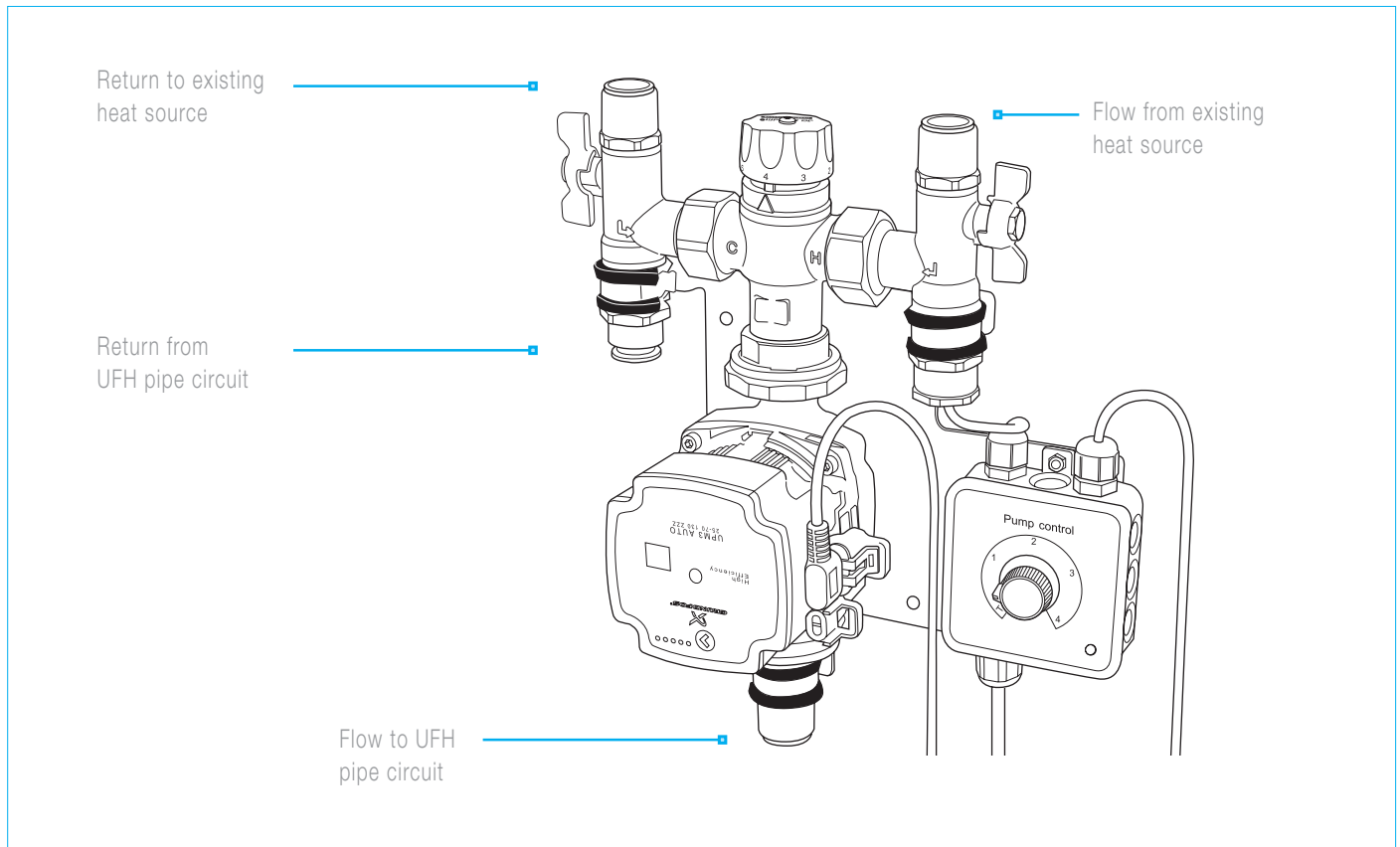

## Step 9

Use the method relevant to your installation:

### Room Pack - 20m<sup>2</sup>

Push the underfloor heating pipe into the 'Flow to UFH pipe circuit' on the control unit, using the pipe insert supplied. Push the return pipe into the 'Return from UFH pipe circuit' on the control unit, using the pipe insert supplied. If two pipe circuits are needed to heat the area, Speedfit tee and stem elbow would be required to split the flow, do not use more than 100m of pipe in any one circuit.

### Room Pack - 30m<sup>2</sup>

As two pipe circuits are used to heat the area, use the provided Speedfit tee and stem elbow to split the flow and connect the pipe to the 'Flow to UFH pipe circuit' on the control unit. NB: A pipe insert is not required for a stem elbow. Using the same method push the return pipes into the 'Return from UFH pipe circuit' on the control unit.

# Connecting to an existing heating system

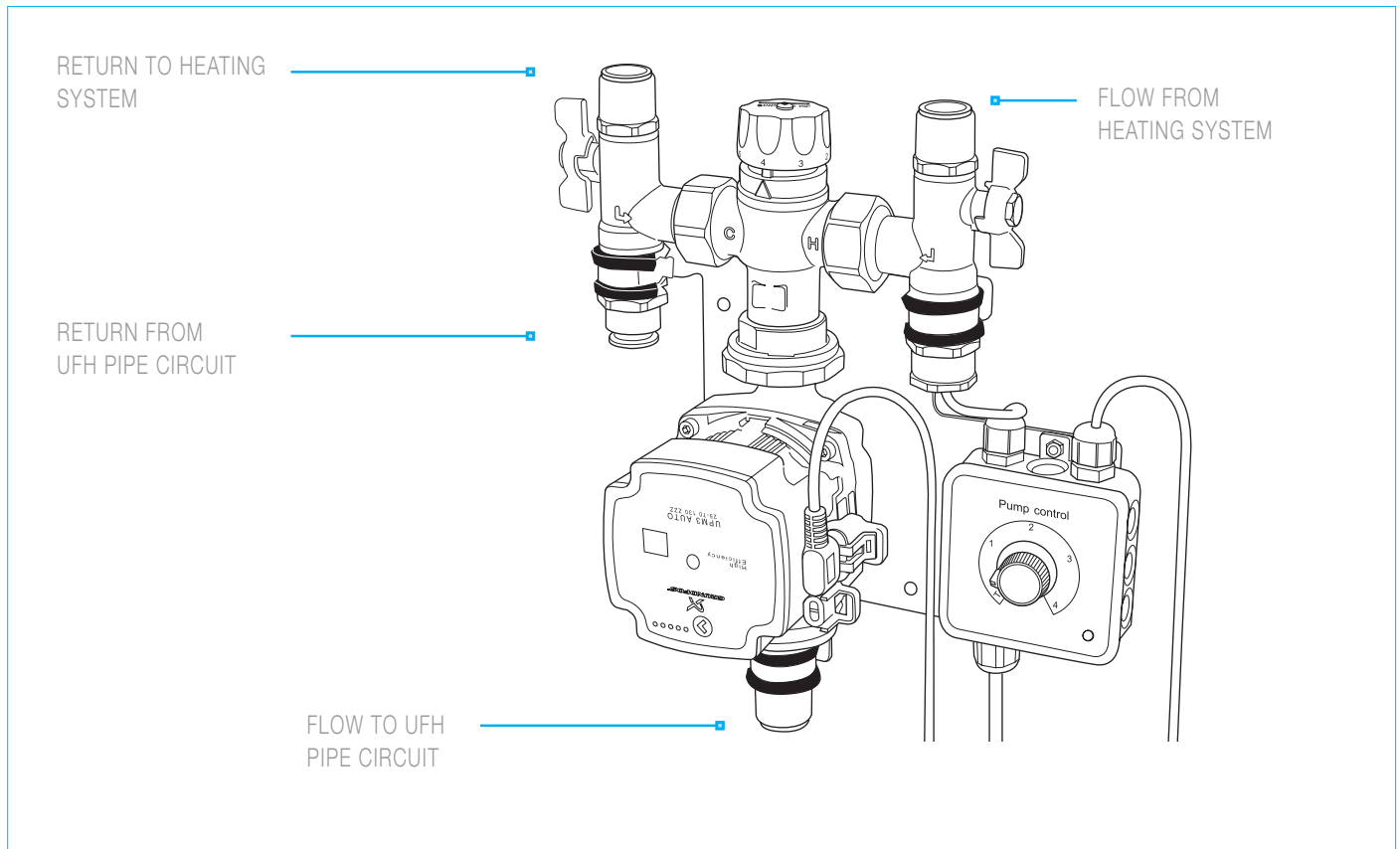

## Step 10

The next step is to connect the existing heating supply to the control unit. There are different ways to achieve this so before you start decide on your preferred option.

### Option 1– control unit with direct control of the boiler

Most central heating systems only have a hot water and central heating circuit. If the room with the underfloor heating is to be controlled independently, a third circuit is required. This is achieved by installing a motorised valve between the boiler and underfloor heating system.

Motorised valves can be used to control multiple circuits on conventional and combination boiler systems. This will enable the control unit's sensor to switch the pump on when the water from the boiler is above the set temperature. The pump will be switched off when the water from the boiler drops below the set temperature.

[Diagram on next page](#)



## Option 1 - control unit with direct control of the boiler

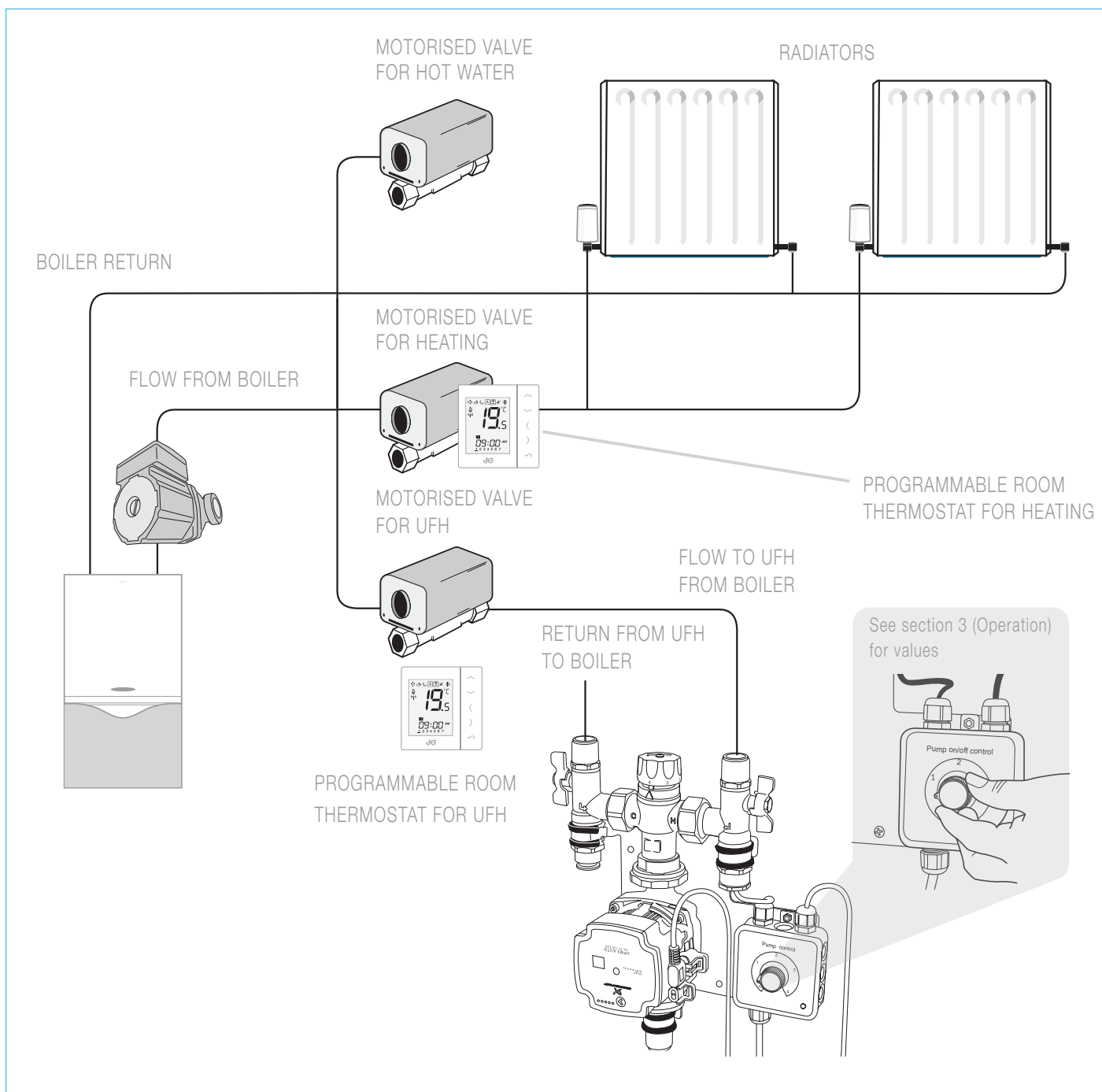

The use of motorised valves to provide multiple circuits can be applied to conventional and combination boilers.

If adding a third circuit to an existing system that is using a 3-port motorised valve (Y Plan), the valve should be replaced with a 2-port motorised valve (S Plan and S Plan Plus).

## Option 2 – connecting to the existing heating circuits without using a thermostat

In an installation without a dedicated underfloor heating circuit for the control unit, the thermostat will not independently switch the boiler on. This means that the control unit will only provide heat to the UFH circuit if the main heating system is on.

The built in sensor will turn the pump on when the water from the boiler to the control unit is above the set temperature and turn it off when the water from the boiler drops below the set temperature.

The unit will only need to be wired into a conventional socket, or fused spur.

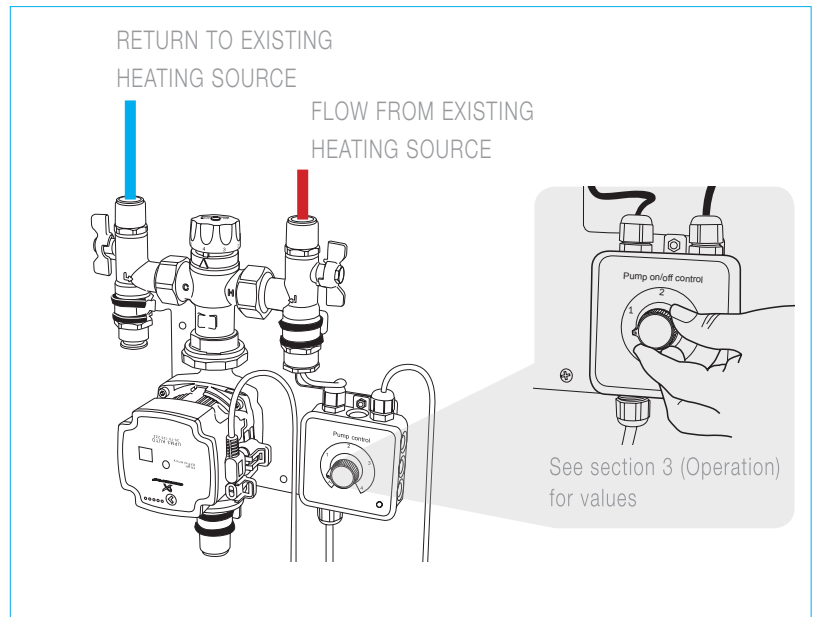

## Option 3 – connecting to the existing heating circuits using a thermostat

This option should only be used when connecting to an existing heating system without a dedicated underfloor heating circuit.

Connecting the control unit in this way only gives partial control, as it will independently turn the boiler on or off. Instead, the control unit will switch off when the room reaches the temperature set on the room thermostat. The thermostat cannot turn the boiler on so the control unit will start and stop circulation as required when the boiler is on but there will be no heating if the boiler is switched off at the main heating circuit.

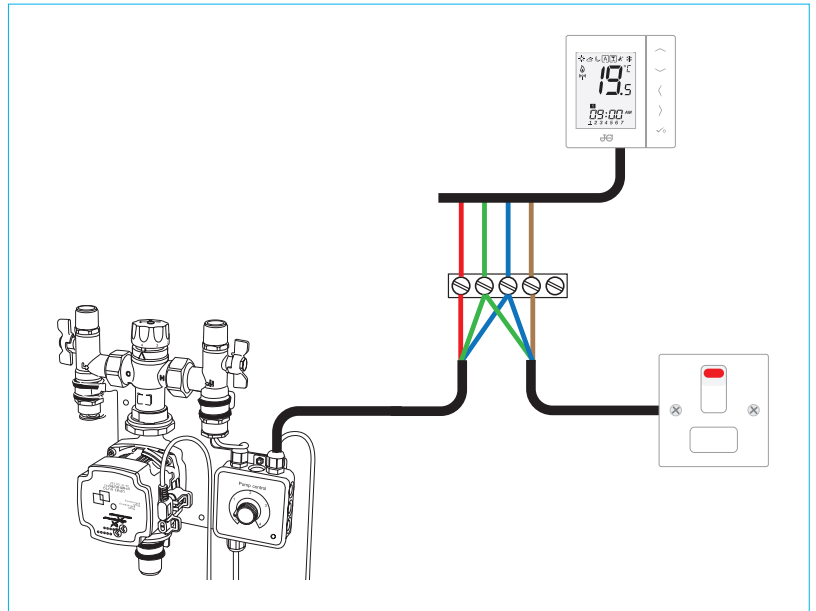

### ■ Hints & Tips

Option 2 and 3 are only suitable when there is no dedicated underfloor heating circuit from the boiler and where you are connecting to the nearest radiator supply pipe.



# Laying the floor screed

## Step 11

Lay the screed as soon as possible after the pressure test making sure there is good contact with the pipe circuit. Consult your screed supplier regarding the correct depth (sand and cement screed is typically 65-75mm thick).



---

## Step 12

Allow the screed to dry naturally in accordance with the screed manufacturer's instructions. Drying times vary but it is normally 28 days for sand/ cement screed. The UFH system must not be used to speed up the drying process otherwise it could cause damage.

The system should not be turned on until the screed has been allowed to cure as turning the heating on too early could damage the screed. The control unit has an in-built water temperature control and should be run first at a lower setting to allow the screed and floor finish to heat up slowly before increasing to its final running temperature. Start up and final temperatures are detailed in the Speedfit Underfloor Heating Installation Guide.



# Installing JG Aura heating controls (thermostat)

The Room Pack comes with a programmable room thermostat allowing you to control the room heating time and temperature.

## Step 13

When installing the thermostats electrical works must be fitted and tested by a competent person and comply with IEE Regulations before it can be connected to a mains voltage. If you have opted for the wireless thermostat you will also need to pair it to the system as detailed in the JG Aura Installation Guide.



---

## Step 14

Once the installation is complete all you need to do is set up the desired heating programme on the thermostat. Control can be 5-day, 2-day or 7-day with up to 6 different time and temperature settings per day.

Please refer to the JG Aura Heating Control Guide on the JG Speedfit Underfloor website for instructions on programming.

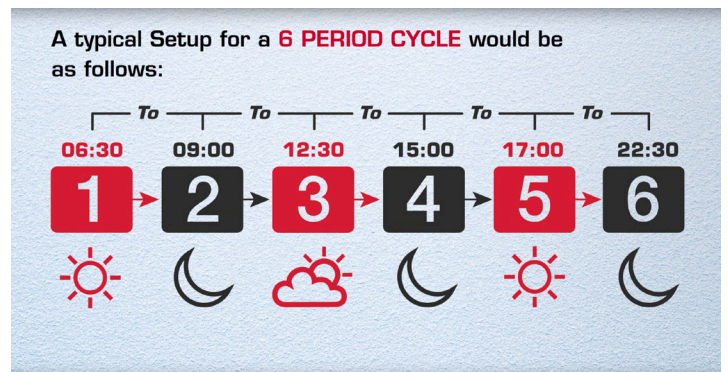

---

# 6. Help & Support

All of our installation guides and easy to follow videos can be found on our website:

<http://www.johnguest.com/speedfit/technical-support/>

**Speedfit Support: 01895 425333**